

# FIRST-LINE tip



✓ EFFIZIENZ +

**HEITEC**  
HEISSKANALTECHNIK

# FIRST-LINE

## Type 01.010.

## Type 01.020.



### PRODUCT FEATURES

- Installation diameter:  $\varnothing$  13 / 15 / 20 / 26 / 30mm
- Nozzle lengths: 22 - 350mm
- Melt channel diameter:  $\varnothing$  3 / 4 / 5 / 6 / 9mm
- Shot weight/nozzle: 0,05 - 1800g
- Heat-conductive / wear-resistant tips with metallic or screw-type connection
- Up to 5mm tip extension possible
- Heating with metallic connection 230V, external heating
- Excellent vestige quality
- Suitable for all types of plastic
- Excellent temperature profile
- Optimal thermal separation between nozzle and mould
- Also available as individual nozzle and valve-gate nozzle
- Easy to install
- Standard sizes in stock
- Efficient use of energy and resources
- Can be integrated into HOT HALVES and FLEX-IN systems
- Additional thermal separation between nozzle heating pipe and body for optimal isolation from mould
- Handles up to 2000 bars of injection pressure

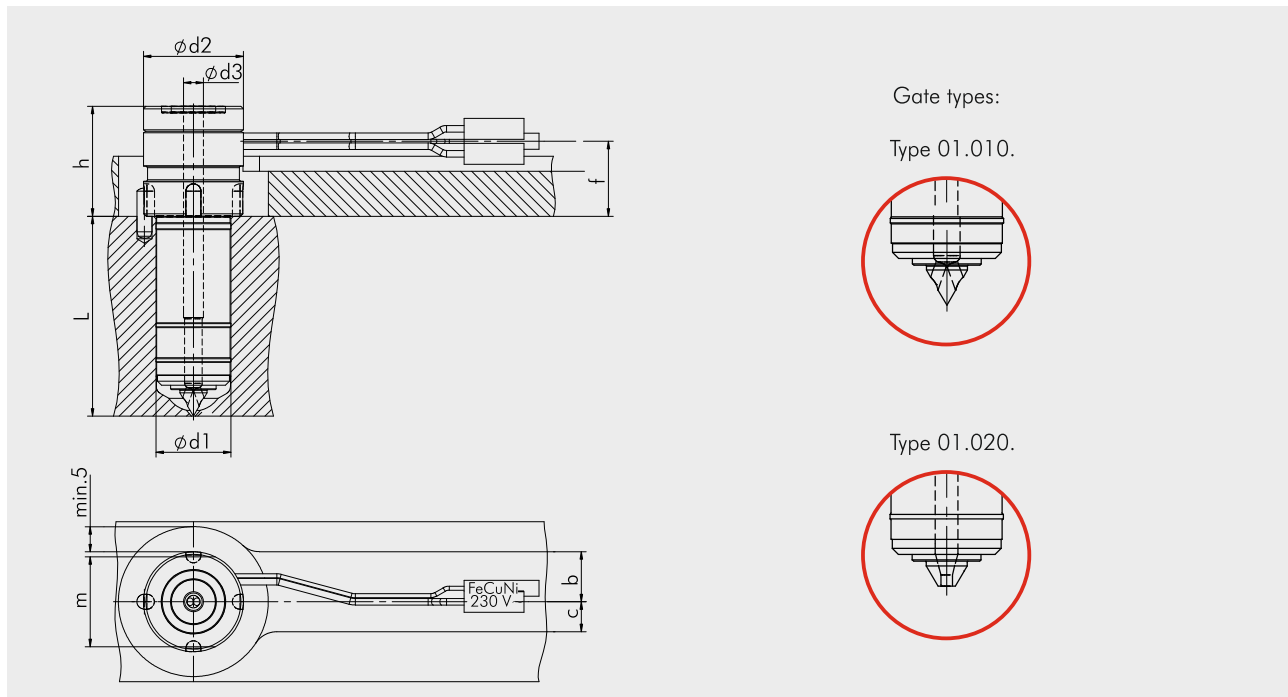

Type	d2	d1	d3	h	f	L	m	c	b	D
01.010/020.13.	17	13	3	15+22	9+16	22-80	14,8	6	10	0,4-1,2
01.010/020.15.	20	15	4	15+22	9+15	22-120	18	6	10	0,6-1,5
01.010/020.20.	30	20	5	22	15	30-120	27	6	10	0,8-2,5
01.010/020.26.	40	26	6	30	21	40-120	36	6	10	1,0-3,6
01.010/020.30.	40	30	9	30	21	60-100	36	6	10	1,2-4,2

