

FLAT-LINE



✓ EFFIZIENZ +

HEITEC
HEISSKANALTECHNIK

FLAT-LINE

Type 01.041.

PRODUCT FEATURES

- Nozzle lengths: 25 - 120mm
- Melt channel diameter: 2,5 - 6mm
- Shot weight/nozzle: 0,01 - 50g
- Heat-conductive / wear-resistant tips with metallic or screw-type connection
- 230V external heating
- Supports individually controlled cavity spacing starting at 4.5mm
- Suitable for plastics with up to 30% filler content
- Short cycle times thanks to low heat input into the mould
- Replacement of heaters and temperature sensors can be performed by customer
- Excellent suitability for reel-to-reel injection moulding
- Efficient use of energy and resources

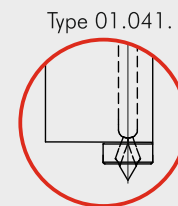
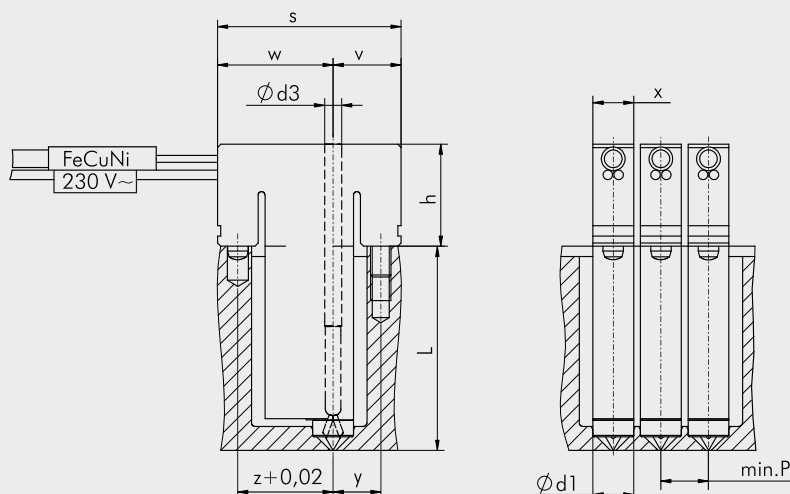

Type	s	d1	v	w	h	L	y	z	d3	min. P	x
01.041.05.	27	5	10	17	15	25-60	7	14	2,5	5,5	5
01.041.06.	27	6	10	17	15	25-60	7	14	2,5	7	6
01.041.08.	31	8	14	17	15	30-80	11	14	3	10	7
01.041.10.	38	10	15	23	22	40-80	11	19	4	14	10
01.041.16.	72	16	27	45	22	40-120	16,5	34	6	21	16

