

# STAR-LINE CROWN



✓ EFFIZIENZ +

**HEITEC**  
HEISSKANALTECHNIK

# STAR-LINE

## Type 01.072.

### PRODUCT FEATURES

- Nozzle for radial arrangement of parts
- Built-in diameter of nozzle: 44 - 80 mm
- Melt channel diameter: 6/ 9mm
- Nozzle lengths: starting at 100 mm
- Arrangement of parts:  $\varnothing 56$  -102mm
- Part weight/tip: 0.05 - 100g
- Number of tips/nozzle: 1 - 8
- Heating with metallic connection
- 230V, external heating
- No separation of mould inserts required
- Tip exchange and gate well area cleaning on the machine only take a few minutes
- Optimal gate quality: Nozzle expansion is compensate within the nozzle. This ensures the centring of the nozzle tip in the gate
- Excellent temperature profile, making it equally suitable for engineering resins such as PA, PBT and PEEK
- Efficient use of energy and resources
- Great design freedom thanks to the slim nozzle design

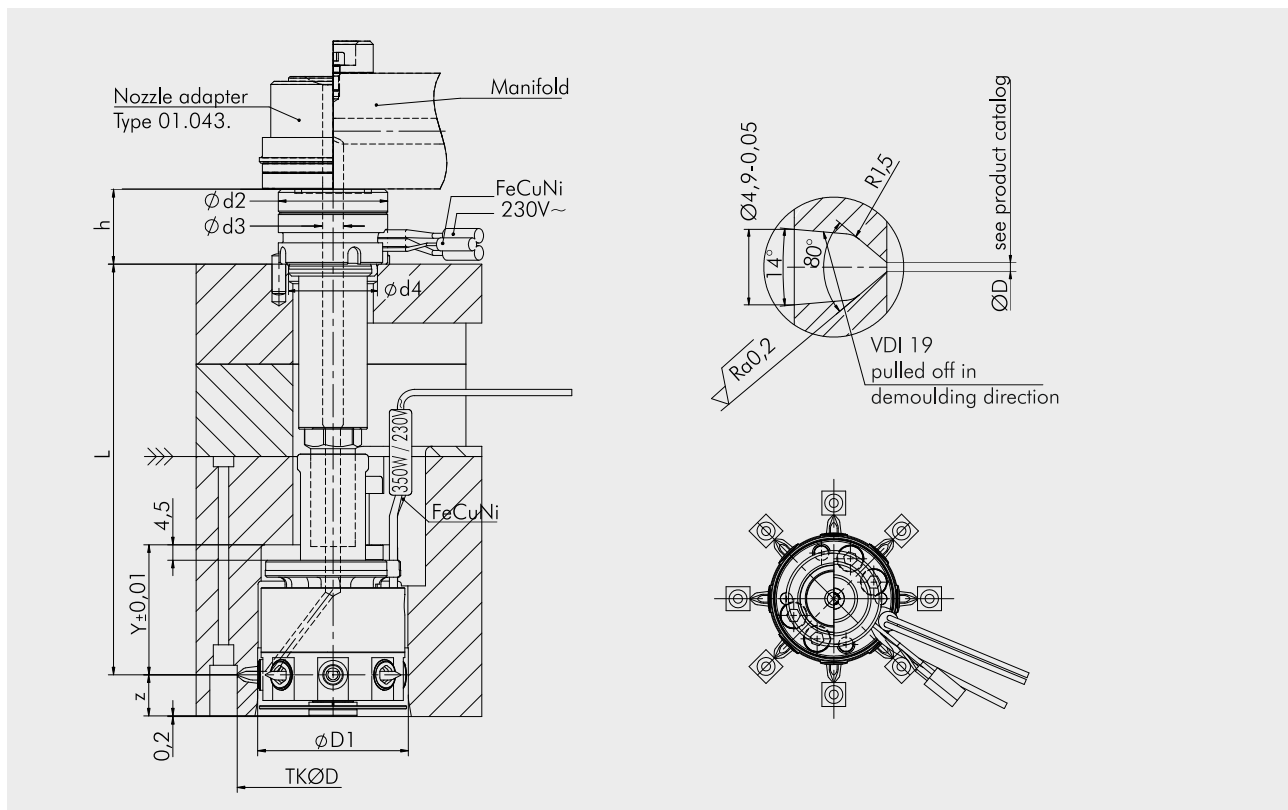

Type	D	n	L	D1	d2	d3	d4	y	h	z
01.072.44.	56	1 - 8	100-200	44	32	6	26	38	22	12
01.072.64.	86	1 - 8	120-200	64	46	9	38	42,5	27	12
01.072.70.	92	1 - 8	120-200	70	46	9	38	53	27	14,95
01.072.80.	102	1 - 8	120-200	80	46	9	38	53	27	14,95

