

X-PURE[®]-LINE



✓ EFFIZIENZ +

HEITEC
HEISSKANALTECHNIK

X-PURE®-LINE

Type 01.058.



PRODUCT FEATURES

- Installation diameter: 17- 42mm
- Nozzle lengths: 40 - 250mm
- Melt channel diameter: 4 -13mm
- Shot weight/nozzle: 0,1 - 5000g
- Tips available in a variety of types
- Screw-type nozzle tips
- Plug-type heater and temperature sensors
- 230V, external heating
- Suitable for all types of plastic
- Excellent temperature profile
- All components can be replaced by the customer
- Efficient use of energy and resources
- Quick colour changes thanks to smaller gate well area
- Shorter cycle times thanks to low heat input into the mould
- Also available as individual nozzle and valve-gate nozzle
- Can be integrated into HOT HALVES and FLEX-IN systems

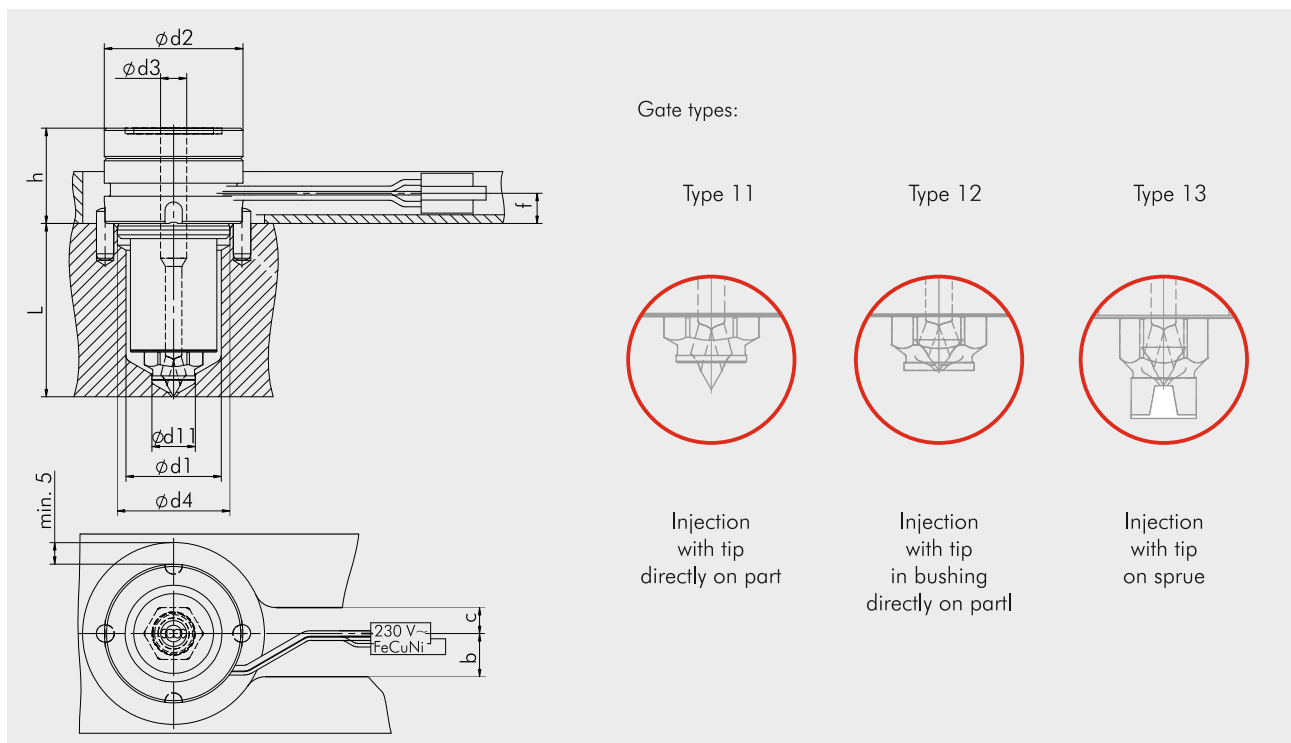

Type	d2	d1	d3	d4	d11	L	h	f	b	c	tip
01.058.17	28	17	4	22	7	40-250	22	7	10	6	11-23
01.058.22	32	22	6	26	10	40-250	22	7	10	6	11-23
01.058.34	46	34	9	38	13	40-250	27	6,6	20	6	11-23
01.058.42	54	42	13	42	20	40-250	30	12,5	20	6	11-23

