

VG-FLAT-LINE



✓ EFFIZIENZ +

HEITEC
HEISSKANALTECHNIK

VG-FLAT-LINE

Type 61.042.

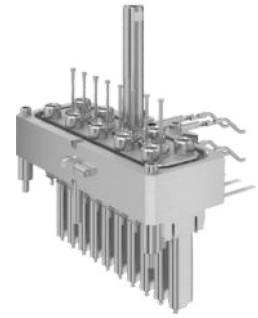

PRODUCT FEATURES

- For cavity spacing starting at 11 mm
- Cavity spacing starting at 5.8mm upon request
- Nozzle lengths 50 - 250mm
- Shot weights 0.02 - 500g
- Melt channel diameter 4/ 5mm
- Available gate type: type 61
- Replacement of heaters and temperature sensors can be performed by customer
- Nozzle for narrow cavity spacing or narrow installation spaces
- Suitable for all types of plastic
- Almost unlimited design freedom thanks to minimal space requirement
- Excellent suitability for strip overmoulding and reel-to-reel manufacturing

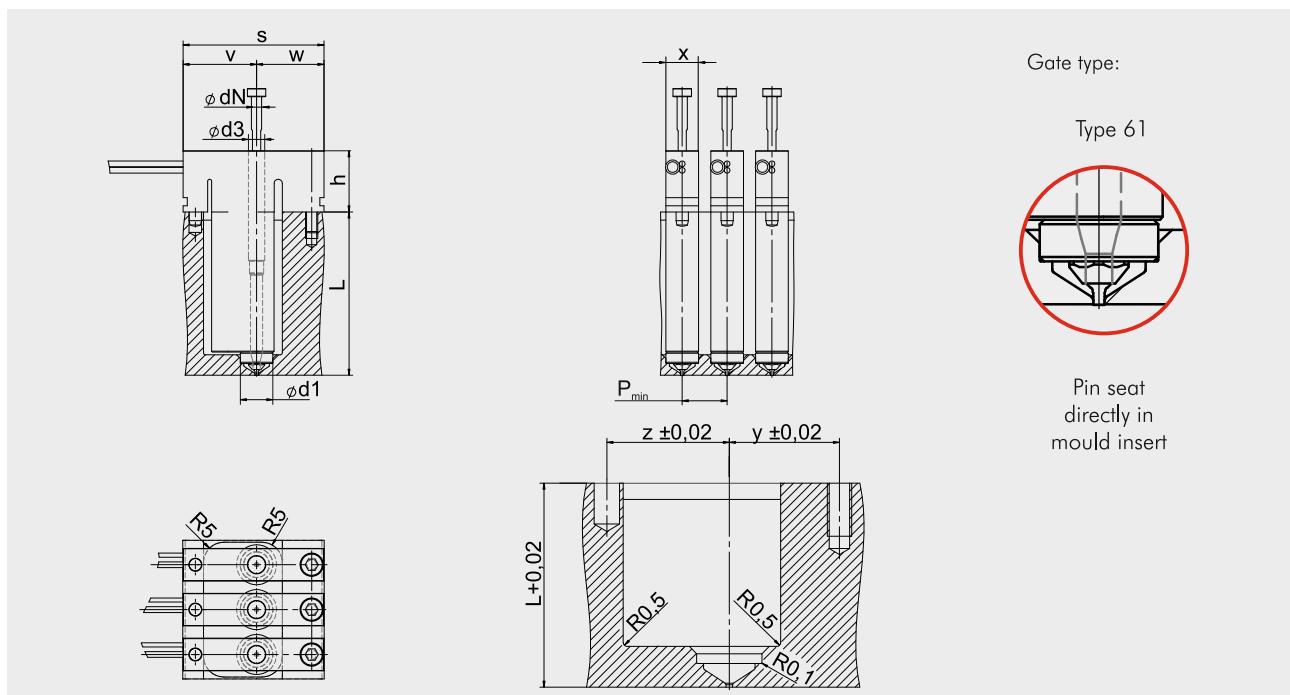

Type	s	d1	d3	v	w	dN	h	L	x	y	z	P _{min}
61.042.08.	34,5	8	4	18	16,5	2,5	15	50 - 80	8	13,5	15	11
61.042.10.	40	10	5	25	15	2,5	22	50 - 100	10	11	21	14

